

# 3M™ Scotchpak™ 1022 Release Liner

Fluoropolymer Coated Polyester Film

## Description:

The unique coating on this proprietary liner provides premium release from silicone skin contact adhesives, as well as acrylate, polyisobutylene (PIB) and rubber based pressure-sensitive adhesives. The product is supplied in roll form for use in the fabrication of transdermal, topical and transmucosal drug delivery systems.

- Transparent
- Occlusive
- 2-year shelf life
- Excellent chemical stability
- Fluoropolymer release coating applied to one side
- Manufactured for use in pharmaceutical products

## Liner Properties:

Test data presented are average values and are not intended to be used for specification purposes. Liner release test uses a restricted, proprietary test adhesive. Customer release values will be unique for each system formulation.

Properties:	Nominal Values	Nominal Values
	U.S.	Metric
<b>Caliper</b>	3 mils	76.2 $\mu\text{m}$
<b>Liner Release</b>	<100 g/in.	<1.0 N/25.4 mm
<b>Tensile</b>		
MD	60 lbs./in.	267 N/25.4 mm
CD	70 lbs./in.	311 N/25.4 mm
<b>Elongation</b>		
MD	50 %	50 %
CD	50 %	50 %

Note: 3M test methods and product specifications available upon request.

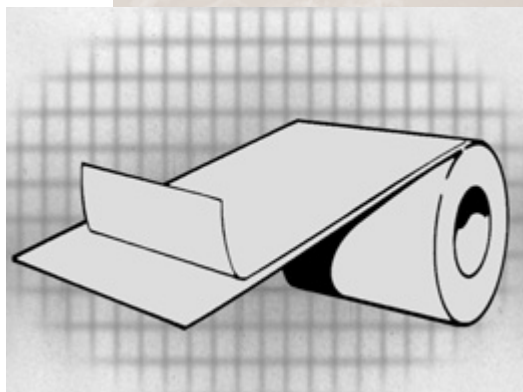

Liners

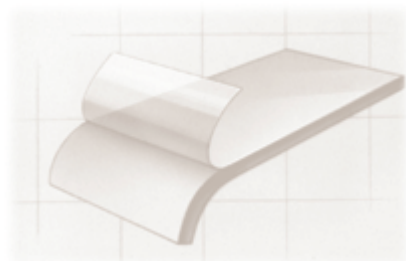

**3M Drug Delivery Systems**

# 3M™ Scotchpak™ 1022 Fluoropolymer Coated Release Liner

## General Information:

	Nominal Values U.S.	Nominal Values Metric
<b>Length:</b>		
Maximum	2400 yds. on 3 in. I.D. cores	2193 m on 76 mm I.D. cores
Approximate roll diameters	2400 yds. – 18.5 in. 1500 yds. – 14.5 in. 1000 yds. – 12.0 in. 500 yds. – 9.0 in.	2193 m – 47 cm 1372 m – 37 cm 914 m – 30 cm 457 m – 23 cm
<b>Width:</b>		
Maximum	45 in.	114 cm
<b>Sample Roll:</b>	25 yds. × 6 in.	23 m × 15 cm
<b>Minimum Order Quantity:</b>	60 yd <sup>2</sup>	50 m <sup>2</sup>

## Traceability:

Each roll and shipment will contain a lot number which is traceable through production records to input materials and process conditions. Material traceability will be in compliance with United States current Good Manufacturing Practices.

## Product Safety:

Product safety is characterized by the following evaluations:

- Primary Skin Irritation
- USP Plastics Class V Extraction
- Acute Systemic Toxicity
- Intracutaneous Irritation

## Storage Conditions:

The product should be stored at temperatures between 32–86°F (0–30°C) and relative humidity less than 75 percent. The product will maintain the stated performance, for a period of two years from the manufactured date, when stored under recommended conditions.

## Product Use:

Customer is solely responsible for determining the suitability of Transdermal Components for the intended use and performing any necessary safety testing.

## For More Information, Please Call:

**U.S.A.** (800) 643-8086

**Europe** 44 (1509) 613070

**Japan** (03) 3709-9671

[www.3M.com/DDS](http://www.3M.com/DDS)



See 3M General Conditions of Sale for Transdermal Components for warranty information and other terms of sale.

## 3M

### Drug Delivery Systems

3M Center, Building 275-3E-10  
St. Paul, MN 55144-1000  
U.S.A.  
(800) 643-8086  
FAX (651) 633-2072

### 3M Health Care Ltd. Drug Delivery Systems

Morley Street  
Loughborough  
Leicestershire, LE11 1EP  
England  
44 (1509) 613070  
FAX 44 (1509) 613099

### 3M Drug Delivery Systems Japan

スリーエムヘルスケア株式会社  
薬事部  
本社：158-8583東京都世田谷区玉川台2-33-1  
(03) 3709-9671  
FAX (03) 3709-8754

Scotchpak is a trademark of 3M.  
Copyright © 3M 10/04.  
All rights reserved.  
70-2008-9188-8