

## Instructions for completing 3M™ Pushrod Order Form

1. To help expedite your order, please be sure to have the following information:

- **Length of pushrod**

The following method is used by 3M to measure the length of the pushrods:

**Flat to Flat (or actual length):**

The flat to flat measurement is calculated by measuring the length of the pushrod with a caliper. Flat to flat length will be shorter than the theoretical length by the amount lost when oil holes are drilled into the end caps (see diagram below). This measurement can be affected by the variability in hole diameter, chamfer around the hole, and the alignment of the pushrod in the caliper itself.

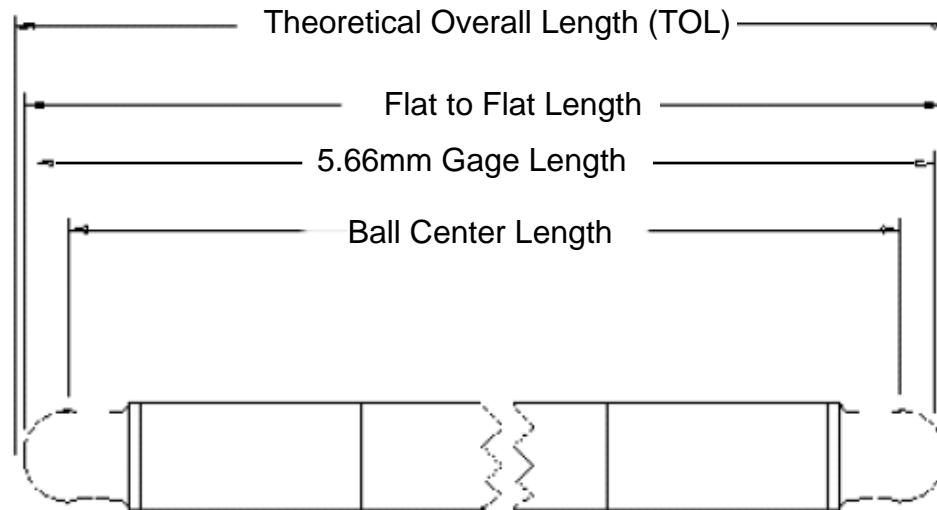







The easiest and most accurate solution is for you to send a pushrod of the length you require to 3M and we will measure and duplicate that length within our tolerance of  $\pm .005$ ". If you do not have a sample pushrod or have questions, please contact us at the number on the order sheet and we will help you to accurately determine your required length.

Call us if you have any questions or other requirements.

○ **End cap style required**

The following table lists the styles of end cap offered by 3M. Be sure to specify if the pushrod is being ordered without end caps, or if you require a different style end cap.

Diameter	Standard End cap style	
3/8"	Regular 5/16 Ball End	
	Regular 3/8 Ball End	
	3/8" Bullet End	
7/16"	Regular 5/16 Ball End	
	Long 5/16 Ball End	
	3/8" Ball End	
1/2"	Contact 3M with specified endcap requirements	

○ **Sales tax exemption status**

Is your company exempt from sales tax? If so, please provide your company tax exemption certificate, or complete the 3M Tax Exempt Form ([click here for form](#)).

If your company is not exempt, sales tax will be added to the invoice for the ship-to location/state.

2. Review the attached 3M Terms and Conditions on the sale of pushrods ([click here to view the terms and conditions](#)).
3. Complete the following form and return to 3M Customer Service via fax at 1-888-993-9185. Call 1-888-650-5116 if you have any questions.

# 3M™ Pushrod Order Form

Customer Purchase Order No.	Order Date	Total Units Shipped (completed by 3M)	Date Shipped (completed by 3M)	Sales Tax Status		Invoice Number (completed by 3M)
				Exempt _____	Taxable _____	

<b>Ship To:</b>	Domestic_____	International_____	<b>Bill To:</b>  <i>Same as Ship To</i> -----	Name	Name
	Company			Company	
	Address			Address	
	City			City	
	State	Zip		State	Zip
	Phone	Fax		Phone	Fax
	Email Address				

<b>Shipping Instructions</b>	___ UPS Ground <span style="margin-left: 200px;">___ UPS Blue (2-day) Air</span> <span style="margin-left: 200px;">___ UPS Red (next-day) Air</span>
	Collect Courier Name _____ Account Number _____ (Note: Freight charges are normally prepaid & added to invoice unless shipped collect on customer account number if provided)

<b>Payment Instructions</b>	Purchase Order Number: _____
	Preferred Payment Method/Terms: <span style="margin-left: 50px;">_____ Net 30 Days</span> <span style="margin-left: 50px;">_____ Credit card</span> If paying by credit card, contact 3M Customer Service at 1-888-650-5116 with the following information: Credit card type (Visa, MasterCard, American Express), number, and name on card



**Additional Information**

Was sample pushrod sent to 3M for confirmation of dimensions (check one)? Yes \_\_\_\_\_ No \_\_\_\_\_

If yes, quantity sent \_\_\_\_\_ Date sent \_\_\_\_\_

Return rod when finished: Yes \_\_\_\_\_ No \_\_\_\_\_

Drawing attached: Yes \_\_\_\_\_ No \_\_\_\_\_

Drawing number \_\_\_\_\_ Revision \_\_\_\_\_ Date \_\_\_\_\_

**Terms and Conditions**

3M will process your order according to 3M's business unit standard payment terms and the 3M Metal Matrix Composites Terms and Conditions of Sale ("Terms"), which are incorporated by reference. Click [here](#) for a copy of the Terms. 3M does not accept any additional or different terms or conditions stated in a Purchase Order, or any other document submitted by buyer, and any such terms and conditions are expressly rejected. All orders are governed exclusively by the Terms,

**Delivery:** Contact 3M for delivery.

Fax to:

3M Metal Matrix Composite Customer Service

Fax: 888-993-9185

Email to: [metalmatrix@mmm.com](mailto:metalmatrix@mmm.com)

Questions?

Contact 3M Customer Service: 1-888-650-5116

Ship sample rod(s) and drawing(s) to:

Bob LeClaire

3M Customer Service

3M Center, Building 223-06-S-04

St. Paul, MN 55144

# 3M Tax Exemption Certificate

Form 8991 - 89 - S

3M Tax Division

3M Center, Building 224-5N-40  
St. Paul, MN 55144-1000

Our files indicate that we do not currently have an Exemption Certificate on file for your organization. Please complete this certificate for **all states in which you are registered** and feel you qualify for an exemption. The following states require specific state forms: **New Jersey, New Mexico, New York, and Virginia.**

State	Registration #	State	Registration #
1.		2.	
3.		4.	

(IF MORE SPACE IS NEEDED PLEASE ATTACH A SEPARATE SHEET)

**Federal ID Number** \_\_\_\_\_

### Reason for exemption:

- |                                     |  |   |
|-------------------------------------|--|---|
| <input type="checkbox"/> Resale     | <input type="checkbox"/> Multiple points of use (services, digital goods, or computer software delivered electronically) | <input type="checkbox"/> Religious or educational |
| <input type="checkbox"/> Direct Pay | <input type="checkbox"/> Industrial production/manufacturing   | <input type="checkbox"/> Government (Federal)     |
| <input type="checkbox"/> Charitable | <input type="checkbox"/> Other _____   | <input type="checkbox"/> Government (other)       |

### Type of business:

- |                                       |   |   |
|---------------------------------------|---|---|
| <input type="checkbox"/> Construction | <input type="checkbox"/> Information, publishing, and communication | <input type="checkbox"/> Manufacturing          |
| <input type="checkbox"/> Retail trade | <input type="checkbox"/> Transportation and warehousing             | <input type="checkbox"/> Wholesale trade        |
| <input type="checkbox"/> Government   | <input type="checkbox"/> Educational and health-care services       | <input type="checkbox"/> Nonprofit organization |
|                                       | <input type="checkbox"/> Other _____                                |   |

*I declare that the information on this certificate is correct and complete to the best of my knowledge and belief.*

<b>Firm Name</b> _____	<b>Signature</b> _____
<b>Address</b> _____	<b>Title</b> _____
	<b>Phone #</b> _____
<b>City, State, Zip</b> _____	<b>Date</b> _____

**This certificate must be signed and returned within 15 days to avoid taxation.**

**FAX NUMBER (651) 737-2500**

**QUESTIONS (651) 733-5172**

## 3M Metal Matrix Composites -- Terms and Conditions of Sale

**TERMS OF PAYMENT.** Terms are NET 30 days from date of invoice in U.S. funds, to customers who have established satisfactory ratings with our credit department.

**ACCEPTANCE.** All orders are subject to final acceptance by the management of 3M Metal Matrix Composites (Seller). Acceptance of any order, whether by acknowledgement or shipment of products, does not constitute acceptance by Seller of any terms or conditions contained in such order, except the identification and quantity of products ordered.

**SHIPMENT.** Products will be shipped F.O.B. point of shipment, with title and risk of loss passing to Buyer upon delivery to carrier at the point of shipment. Seller will exercise all reasonable means to make shipment within the time specified but assumes no liability for loss or damage, for late delivery.

**PRICES.** Orders for immediate shipment will be billed at the price in effect on the date of order receipt. For releases against orders specifying future dated shipments, each release will be invoiced at the price in effect on the date of shipment. Prices are subject to change without notice.

**PRODUCT USE.** Buyer is responsible for evaluating and determining whether Product(s) is suitable and appropriate for Buyer's particular use and intended application. The conditions of evaluation, selection, and use of Product(s) can vary widely and affect the use and intended application of Product(s). Because many of these conditions are uniquely within Buyer's knowledge and control, Buyer must evaluate and determine whether Product(s) is suitable and appropriate for a particular use and intended application.

**SPECIFICATIONS.** The products are made to Seller's specifications and reflect product commensurate with Seller's manufacturing process capabilities. Material not in accordance with Seller's specifications shall be called to our attention immediately. No authorization will be given for return of materials held longer than 90 days after the date of shipment from 3M's facility. If authorization is given for return, return shipment is to be made within 10 days of receipt of authorization.

**EXPORT CONTROL.** The products sold to Buyer under the order are subject to U.S. export laws and regulations. Buyer agrees to comply with all applicable U.S. export control laws and regulations, specifically including, but not limited to, the requirements of the Arms Export Control Act, 22 U.S.C. 2751-2794, including the International Traffic in Arms Regulation (ITAR), 22 C.F.R. 120 et seq.; and the Export Administration Act, 50 U.S.C. app. 2401-2420, including the Export Administration Regulations, 15 C.F.R. 730-774.

**WARRANTY AND LIMITED REMEDIES.** Seller warrants to Buyer that, at the time of delivery to Buyer, the products will conform to Seller's specifications. This warranty shall apply for a period of ninety (90) days from the date of shipment from Seller's facility. THIS WARRANTY IS EXCLUSIVE. SELLER MAKES NO OTHER WARRANTIES, EXPRESS OR IMPLIED, INCLUDING BUT NOT LIMITED TO ANY IMPLIED WARRANTY OF MERCHANTABILITY OR FITNESS FOR A PARTICULAR PURPOSE, OR ANY IMPLIED WARRANTY ARISING OUT OF A COURSE OF DEALING OR PERFORMANCE OR USAGE OF TRADE. If during the ninety (90) day period: (a) the Buyer notifies the Seller promptly in writing upon discovery of any non-conforming products, including a detailed description of such non-conformance, (b) such products are returned to Seller, F.O.B. to Seller's facility, and (c) Seller's examination of such products discloses to Seller's satisfaction that such products do not conform to the foregoing warranty, Buyer's exclusive remedy and Seller's sole obligation shall be, at Seller's option, to repair or replace the non-conforming product or refund the purchase price.

**LIMITATION OF LIABILITY.** Except where prohibited by law, Seller SHALL NOT UNDER ANY CIRCUMSTANCES BE LIABLE TO BUYER FOR ANY DIRECT, INDIRECT, SPECIAL, INCIDENTAL, OR CONSEQUENTIAL DAMAGES (INCLUDING BUT NOT LIMITED TO, LOSS OF PROFITS, REVENUE, BUSINESS, OPPORTUNITY, OR GOODWILL) RESULTING FROM OR IN ANY WAY RELATED TO SELLER'S PRODUCTS OR THE SALE OF SELLER'S PRODUCTS. This limitation of liability applies regardless of the legal or equitable theory under which such losses or damages are sought including breach of contract, breach of warranty, negligence, strict liability, or any other legal or equitable theory. This limitation of liability does not apply to claims for personal injury by a third party or direct damages due to breach of a material obligation under an order.

**EXCUSABLE DELAY.** Neither Seller nor Buyer shall be liable for failure to perform (except for payment by Buyer for Product(s) received) if performance is prevented, restricted, or interfered with by reason of any event or condition beyond its reasonable control, including, but not limited to: Fire or earthquake or other

casualty or accident; inability to procure materials, power, or supplies; war or other violence; any law, order, proclamation, regulation, ordinance, demand, or requirement of any government agency, court, or intergovernmental body; or environmental, health, safety, or regulatory reason as reasonably determined by Seller. A party, when so affected and upon giving notice, shall be excused from such performance to the extent of such prevention, restriction, or interference; provided that the affected party shall use its reasonable efforts to avoid or remove such reason for nonperformance and shall promptly resume performance whenever such reason is removed. In the event of back-order or other limited supply or availability of Product(s) for such reason or any other reason, Seller reserves the right, in its sole discretion and in a manner that it determines to be fair and reasonable under the circumstances, to allocate production capacity related to and/or supply of Product(s) that is in back-order or limited supply.

**CANCELLATION.** Cancellation of an order, of any part thereof, shall be subject to the following terms: Buyer shall pay the contract price of all goods that have been completed. In addition to such payment, the Buyer shall pay whatever portion of the contract price that is equal to the degree of completion of goods in process, effective on the date cancellation is received. Further, the quantity of parts received by the Buyer plus the quantity of work in process must be the total quantity that sets the selling price. A retroactive billing will be made against the corrected quantity-selling price as a part of cancellation charges.

**TECHNICAL INFORMATION AND DATA.** Technical information and data, recommendations, and other statements provided by Seller are based on information, tests, or experience which Seller believes to be reliable, but the accuracy or completeness of such information is not guaranteed. Such technical information and data are intended for persons with knowledge and technical skills sufficient to assess and apply their own informed judgment to the information. No license under any Seller or third party intellectual property rights is granted or implied with this information.

**DISPUTE RESOLUTION.** Seller and Buyer agree to resolve any claims or disputes arising from or relating to an order, agreement or Product(s) by the following sequence of exclusive dispute resolution methods: (a) Good faith negotiations; (b) if necessary, non-binding mediation using a mutually acceptable neutral mediator in accordance with rules and procedures as the mediator shall reasonably establish; and (c) as a last resort, either party may commence litigation, provided, however, that any lawsuit shall be commenced in a federal or state court of competent jurisdiction for the principal place of business of the party against which the lawsuit is filed, and each party consents to the personal jurisdiction of such court. Nothing in this section shall preclude either party from taking any action reasonably necessary to prevent immediate and irreparable harm to that party; provided, however, that any such party remains obligated to resolve the underlying claim or dispute giving rise to such action by means of the dispute resolution methods of this section. A party shall commence efforts to resolve a claim or dispute no later than one year after the cause of action accrues.

**SALES AND EXCISE TAXES.** All sales and excise taxes, federal or state, now or hereafter imposed on the sale of goods covered by this quotation shall be for the account of the Buyer.

**PATENTS AND TRADEMARKS.** Orders for special parts made to Buyer's design are accepted with the understanding that the Buyer will defend at its own expense any suit that may be brought against it or Seller by reason of Seller's manufacture of such parts. Unless otherwise stipulated, Seller reserves the right to have its name or trademark appear on each piece and to use in our display on advertising any pieces or illustration of same.

**MISCELLANEOUS TERMS AND COMPLETE AGREEMENT.** No part of these Terms and Conditions may be amended, modified, supplemented, or waived in any manner whatsoever (including course of dealing or of performance or usage of trade) unless agreed to in writing signed by authorized representatives Seller and Buyer. Neither Seller nor Buyer may assign an order or agreement of which these Terms and Conditions are a part without the prior written consent of the other party. The validity, performance, and construction of these Terms and Conditions, an order, or agreement shall be governed solely by Minnesota law without regard to conflict of law principles. The UN Convention on the International Sale of Goods shall not apply. These Terms and Conditions shall become part of every order, sale, and purchase agreement between Buyer and Seller for Product(s), and any terms or conditions of Buyer or by operation of law that conflict with, differ from or add to them will not become part of an order or agreement unless specifically agreed to in writing by Seller or required by law. All orders are governed exclusively by these Terms and Conditions.

# Available end caps for 3/8" Pushrods



Regular 5/16" Ball End



Regular 3/8" Ball End



3/8" Bullet End

**3M** Specialty Materials Division  
3M Center, Bldg. 223-6S-04  
St. Paul, MN 55144  
Phone: 888-650-5116  
Web: [www.3m.com/mmc](http://www.3m.com/mmc)

# Available end caps for 7/16" Pushrods



Regular 5/16" Ball End



Long 5/16" Ball End



3/8" Ball End

**3M** Specialty Materials Division  
3M Center, Bldg. 223-6S-04  
St. Paul, MN 55144  
Phone: 888-650-5116  
Web: [www.3m.com/mmc](http://www.3m.com/mmc)